

Feasibility of An Energy Efficient Fuel Cell Hybrid Lift: the Main Concept and Design

S. Kaczmarczyk¹, J. Blaszczyk², H. Lei² and R. Smith¹

¹Dept of Engineering, Faculty of Arts, Science and Technology, The University of Northampton, UK

²Shanghai Everpower Technologies Ltd, 1000 Jinsui Road, Pudong, Shanghai, China, 201206

Keywords: regenerative, reversible, fuel cell, hydrogen, solar panels, hybrid elevator, hybrid lift.

Abstract. The latest progress in Fuel Cell (FC) technologies have led to rapid developments in ground vehicle transportation. These technologies could also be considered for deployment in vertical transportation (VT) systems. This paper presents a feasibility study concerning the application of a reversible fuel cell power supply for a solar panel powered lift system operating in a high-rise building. It is assumed that all energy needed to power the elevator system will originate from the solar panels. Energy needed for operation at the low-irradiation periods will be generated from the Hydrogen stored in medium-pressure tanks. The Hydrogen will be produced in a Unitized Reversible Fuel Cell (URFC). When the Grid access is possible the grid will provide emergency power for peak operations or for longer periods of low solar panels output. The URFC unit shall operate in a tandem with a lithium-ion battery, while the size of URFC and battery shall be optimized for overall system minimum cost. The overall conclusion is that the grid-independent lift energy supply system is possible, however the cost and space requirements are major limitations in the seasonal energy storage in Hydrogen form.

1 INTRODUCTION

In the modern high-rise built environment electric motor driven traction elevators are applied for efficient Vertical Transportation (VT) of people and goods. In the traditional system the power to the electric motor is provided by the public mains supply (grid). When the system is raising the out of balance load in the car or in the counterweight the power is taken from the grid. Part of the supplied energy is then stored in the mechanical system as potential energy. On the other hand, when the system is lowering the out of balance in the car or the out of balance of the counterweight the potential energy is being returned to the drive system. This returned energy is referred to as 'regenerated'. Thus, the elevator drive is capable of transferring energy in both directions and is termed as 'reversible' [1].

The recent progress in Fuel Cell (FC) technologies have led to rapid developments in ground vehicle transportation. This paper presents the results of a study concerning the feasibility of a reversible fuel cell power supply system for solar panel powered lift operating in a high-rise building. It is assumed that all energy needed to power the elevator system will originate from the solar panels. Two geographic locations are considered: the best possible solar irradiation in Kampala (Equator) and mid-Europe 52° N parallel (London). The solar irradiation [W/m^2] curves have been derived from available data [2] and are shown in Fig. 1.

In both cases the lift daily energy needs are balanced with the energy stored in a buffer battery set, which has to satisfy two main requirements: store enough energy for daily operations (with reasonable margin for the cloudy weather) and the capability of charge/discharge current at peak power periods (e.g. motor start power, break energy accumulation).

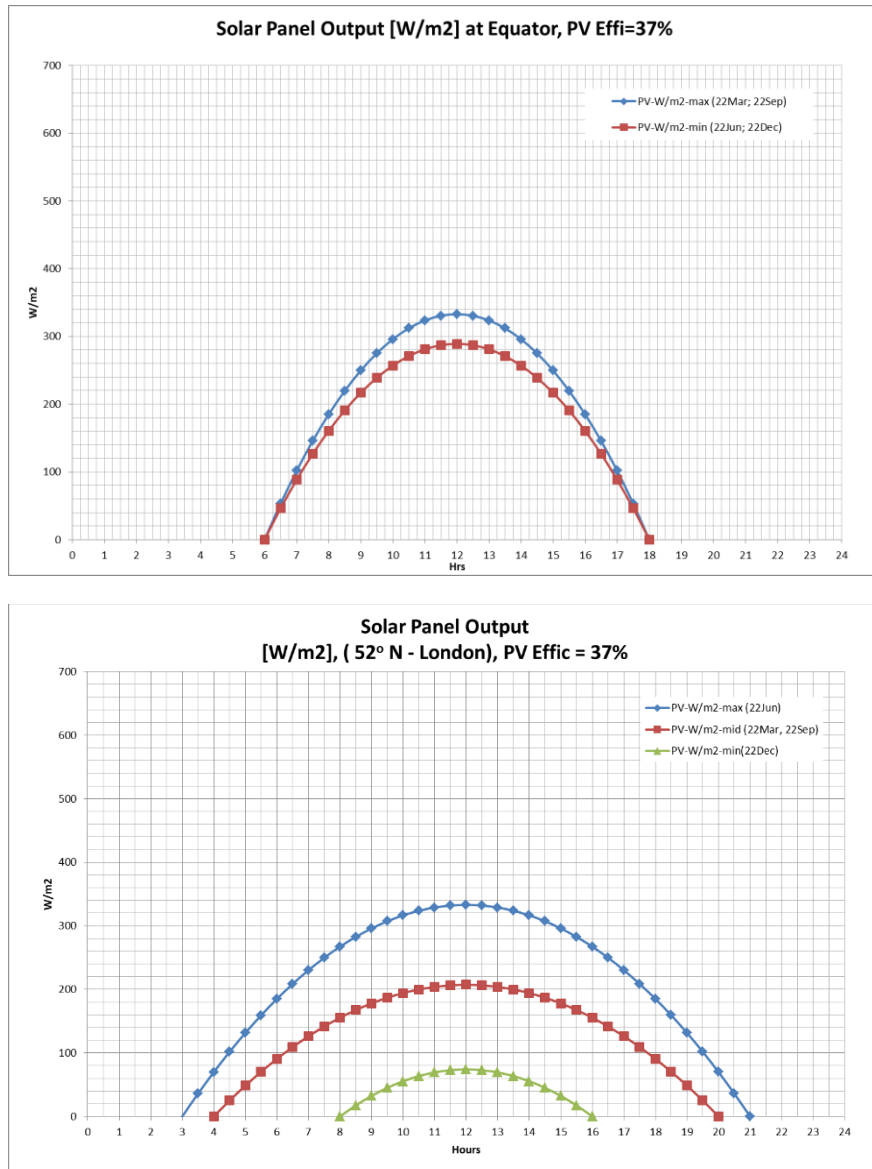

Figure 1 Solar power seasonal fluctuations

2 ENERGY REQUIREMENTS

A simplified model of high-rise lift installation has been considered to generate the lift power requirements and energy consumption. The corresponding building data and the lift installation parameters are shown in Table 1. The lift energy simulation model implemented in a commercial simulation software package Elevate™ [3] has been used to determine the lift power requirements and energy consumption. Siikonen full day office template was used to generate the passenger demand data [4] (see Fig. 2).

Fig. 3 illustrates the simulated cumulative energy consumption data and Fig. 4 shows the averaged power requirements. The lift energy requirements over time is then derived from the cumulative energy data and the corresponding curve is shown in Fig. 5.

The available Sun energy depends on the daily and seasonal irradiation fluctuations. Different energy storage strategies have been adopted to adapt the lift operation scenarios to these cases.

Table 1 Main model data

PARAMETERS	UNIT	VALUE
Building:		
Total building height	[m]	112.4
Average floor height	[m]	3.75
Number of floors		30
Total resident population		300
Average population/floor		10
Lift installation:		
Number of lifts		1
Rated load	[kg]	1600
Car area	[m ²]	2.84
Door open time	[s]	1.8
Door close time	[s]	2.9
Rated speed	[m/s]	5.0
Acceleration	[m/s ²]	1.0
Jerk	[m/s ³]	1.4

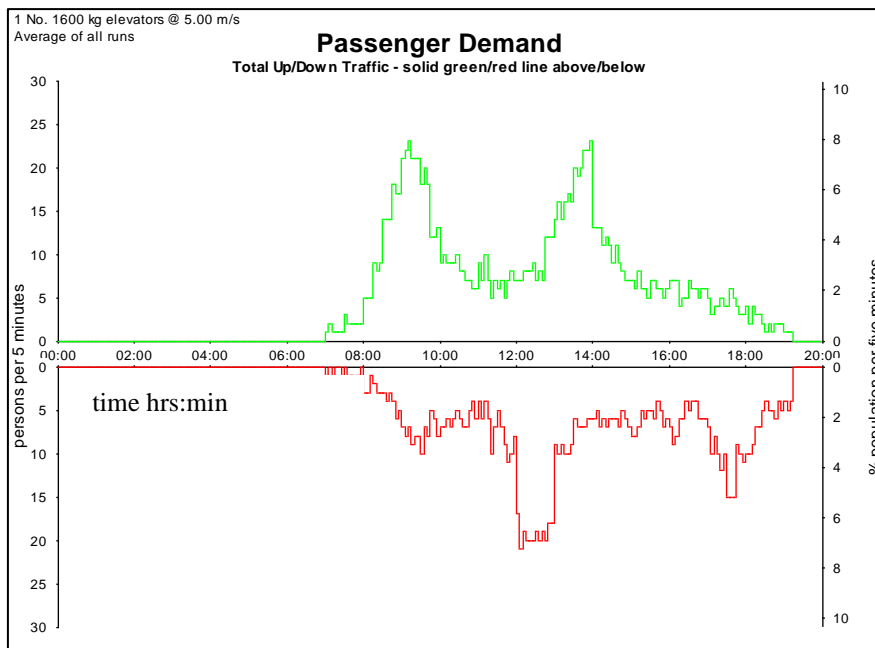

Figure 2 Siikonen full day office passenger demand curves

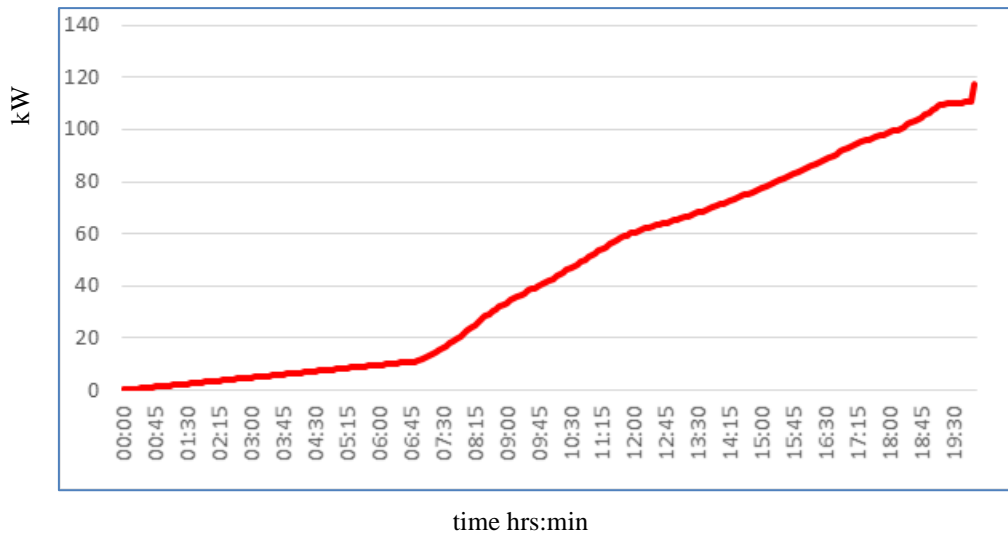

Figure 3 Cumulative energy consumption



Figure 4 Averaged power requirements

These scenarios are outlined as follows.

- A) The energy required is balanced with the energy stored in a daily buffer battery sized for the available Sun energy on:
- a. 22 June at the Equator location
 - b. 22 Sep at the 52°N location.

It is considered that the seasonal energy imbalances/ fluctuations can be covered in the following ways.

- B) The Grid access is possible
- a. The Sun excess energy is stored in the grid at times when the excess energy occurs
 - b. The Lift energy deficits are covered from the grid at times when the Sun energy is inadequate
- C) The Grid access is not possible
- a. The Sun excess energy is stored in the seasonal battery bank when the excess energy occurs, while the energy deficits are covered from the battery bank when the Sun energy is not adequate

- b. The Sun Excess energy is stored in the Hydrogen gas generated (Water Electrolysis) when the excess energy occurs, while the energy deficits are covered from the Fuel Cell operations through Hydrogen conversion into electricity.

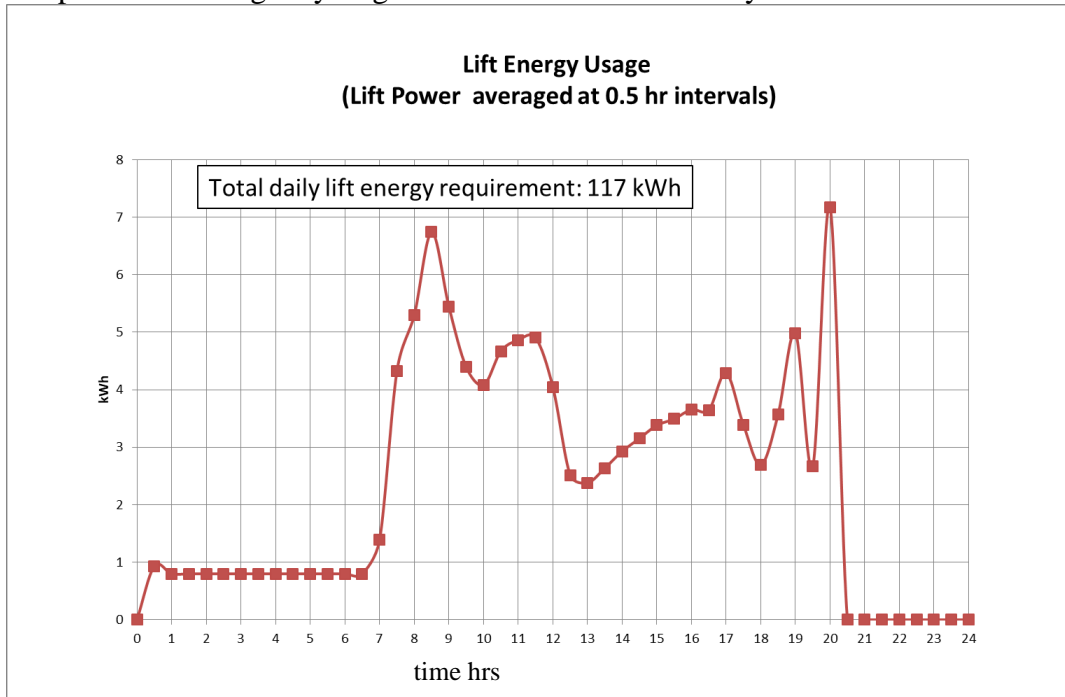

Figure 5 Lift energy consumption

3 POWER SUPPLY SYSTEMS FOR ENERGY STORAGE STRATEGIES

Considering the seasonal energy imbalance/ fluctuations the following lift power supply systems are considered. The diagrams in Fig. 6 and Fig. 7 illustrate the power supply system for scenario B and scenario C, respectively. It should be noted that the diagram in Fig. 7 covers two cases: C)a and C)b, respectively.

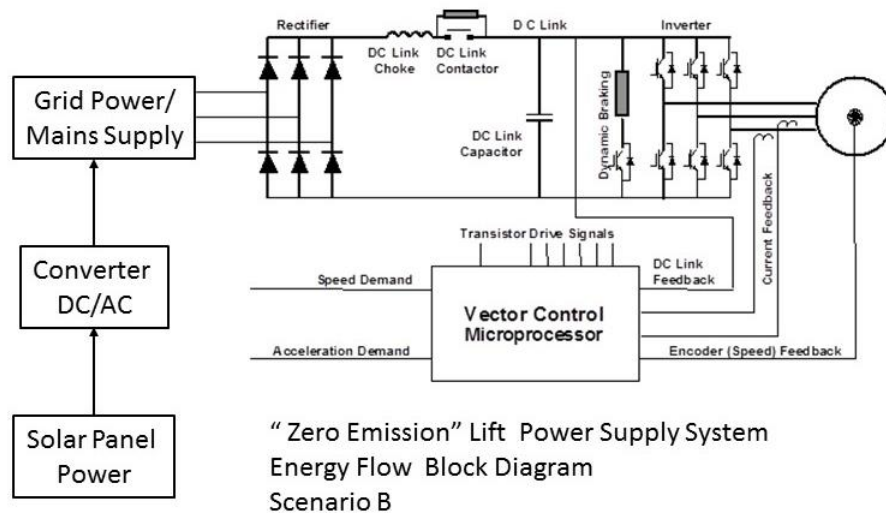

Figure 6 Energy Flow Block Diagram – Scenario B

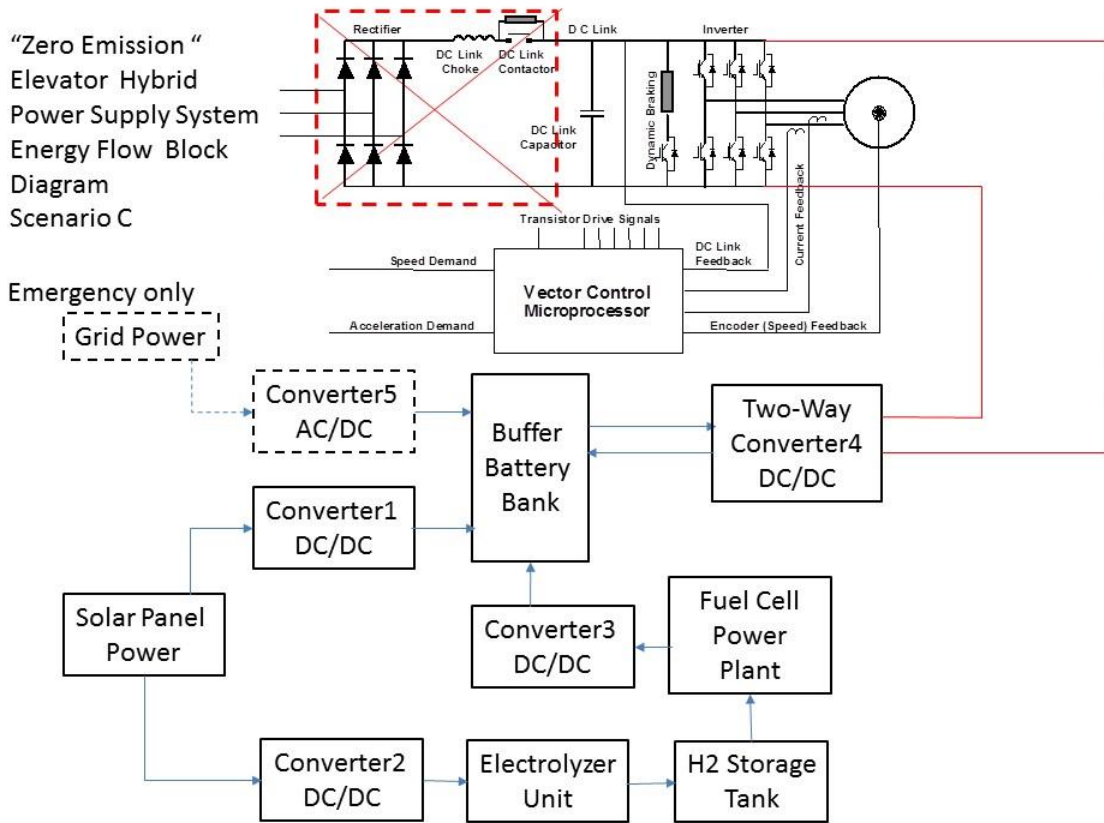

Figure 7 Energy Flow Block Diagram – Scenario C

The Case C)a can be realized when the Fuel Cell/Electrolyser loop is omitted and when the Buffer Battery Bank size is increased to cover the seasonal Sun power fluctuations.

4 BUFFER BATTERY SIZE – DAILY ENERGY FLUCTUATIONS

4.1 Battery Size for Daily Lift Operations

Considering that the lift power requirements don’t correspond to the available Sun energy periods (e.g. day-night) the buffering battery bank is proposed. In this scenario the battery is sized for charging from photovoltaics (PV) solar panels to cover the daily lift energy requirement. The minimum required battery size for daily operations is estimated at 79 [kWh] based on the data shown in Fig. 8 (assuming 100% capacity margin for a “cloudy” day). It should be noted that the lift power requirement is related to the unit area (1m²) of PV panels.

The diagram in Fig. 8 presents the comparison of the Sun’s available energy on the minimum energy day (area below the red line) with the lift’s daily energy requirement (area below the purple line) for locations near the Equator. Sizing PV panels for the minimum energy day is likely to result in a cheaper solution than sizing the PV panels between the blue and red lines and installing any seasonal energy fluctuation compensation device.

For locations near the 52°N parallel the situation is dramatically different. By comparing the graphs in Fig. 1 it becomes clear that the PV panel surface would need to be very large in order to cover the daily lift power requirement on the minimum Sun energy day (22 Dec) –green line, bottom graph. In this case a seasonal energy fluctuations compensation device will likely be required, while the PV panels would be sized to match the annual energy requirement need.

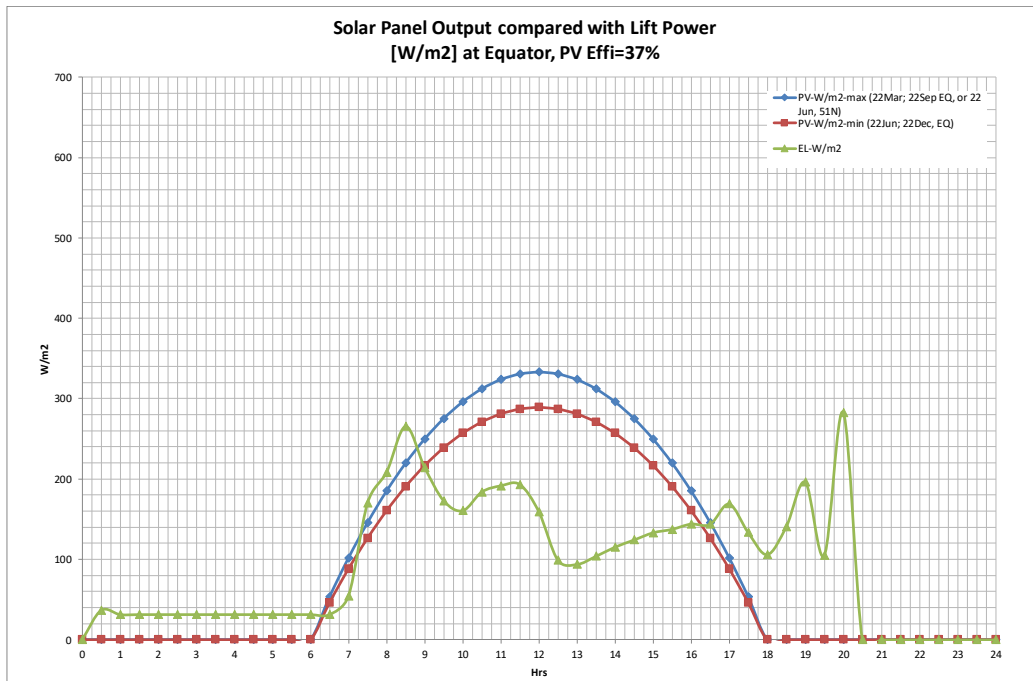

Figure 8 Lift daily energy requirement balanced with PV daily energy on 22 Jun at equator

4.2 Battery Size for Lift Maximum Power Operations

The battery size is also linked to the load power and charge current limitation. A typical 3C Li-Ion battery’s current limitation is 300 [A]. For the selected 100 [Ah], 12 V battery and 165 [kW] peak lift power the minimum buffer battery size is 55 [kWh].

Comparing the battery sizes from cases 4.1 and 4.2, the 79 [kWh] battery bank size is suitable to cover both the daily Sun power fluctuations and the battery charge current requirements.

5 PV PANELS SIZE AND BUFFER BATTERY SIZE

5.1 PV panels size for operations near the equator

The required PV panels surface area for operations near the Equator is determined to be 51 m² assuming the PV conversion efficiency at 37%. The comparison of major component costs is provided in Table 2. There will be no need for the seasonal energy storage – see the maximum (blue) and minimum (red) irradiation curves in Fig. 8.

5.2 Buffer battery size – seasonal energy fluctuations (52°N)

One of the seasonal energy storage options is to use the battery bank. The required battery capacity calculations that have been carried out indicate that this option is not a plausible solution – the energy storage would require 9,906 batteries of 100 Ah each, while the PV Panel surface area would be 50 m². The cost of batteries would then be of about USD 2,000,000.

6 H2 STORAGE AND FUEL CELL SIZE – SEASONAL ENERGY FLUCTUATIONS (52°N)

Some other seasonal energy storage option is the Electrolyser-H2 Storage-Fuel Cell Power System. The main system components are presented in Fig. 7. The operating strategy involves harvesting the Sun energy during high-irradiation periods, converting it into Hydrogen through water Electrolysis, storing Hydrogen in pressurized tanks and converting the Hydrogen back to electricity in the Fuel Cell at the low-irradiation periods. The Electrolysis/Fuel Cell round trip efficiency is around 45 %

which impacts on the required PV panel size/ surface area during the high-irradiation energy harvesting. In this case the needed PV panel surface area is determined as 80 m².

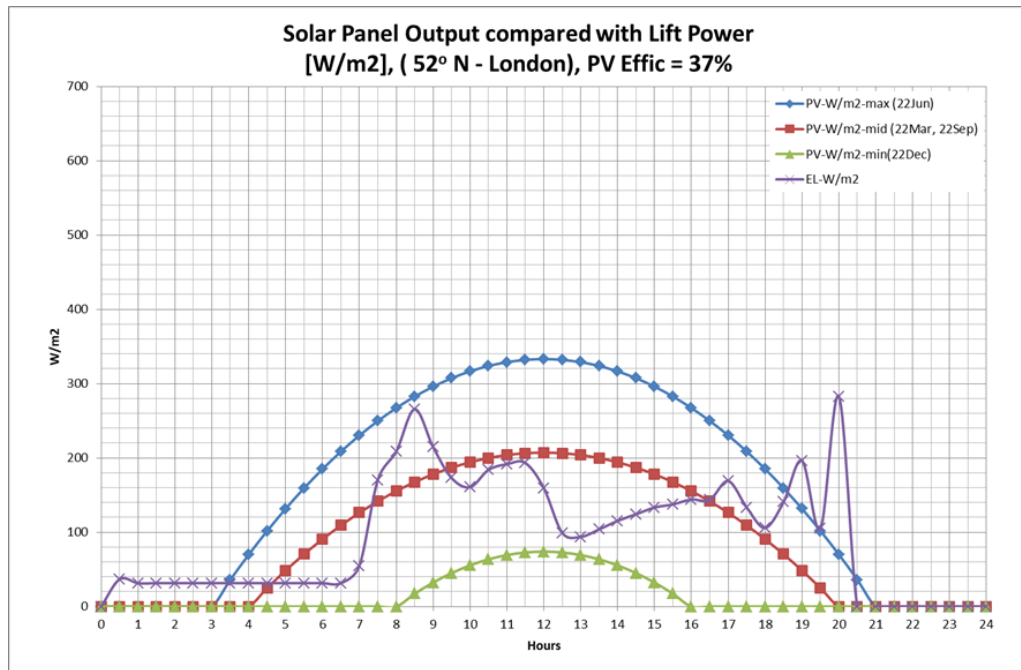

Figure 9 PV Panel Output compared with daily lift power need (PV Panels sized for energy harvesting between 22 March and 22 September)

It should be noted that the lift power requirement is per the unit area (1m²) of PV panels. The required Hydrogen amount for energy storage is 7,925 [Nm³]. The maximum H₂ storage pressure is 130 [barg] due to the Electrolysis process limitations [5]. However, at this point only prototypes of such Electrolysers are available. But bearing in mind the rapid progress in FC technology it can be assumed that the commercial 130 [barg] electrolysers will be available soon and that the high-pressure H₂ compressors will not have to be used due to their high cost.

The required H₂ tanks volume (to store water) is 66 m³, which might be not practical for installation in the high-rise building. The cost of tanks would exceed USD100,000. The cost of 4 [Nm³/hr], 30 [barg] PEM Electrolyser is around USD200,000. The cost of Fuel Cell for H₂ conversion is comparable to the PEM Electrolyser cost.

The Unitized Reversible Fuel Cell technology, which combines Electrolyser and Fuel Cell in one device, is in the prototyping stage and once developed it might cut the H₂ conversion hardware cost by 50%.

Assuming that the required advanced technology is commercially available today, the cost of H₂ production infrastructure would exceed USD 300,000.

7 CONCLUSION

A comparison of the scenarios considered in this study is presented in Table 2. Two geographic locations have been considered in the analysis: near the Equator and at 51°N, which corresponds to London location.

The analysis carried out shows that there is no need for the seasonal energy storage in the areas close to the Equator due to the high solar power availability through the entire year. The daily energy balancing can be covered with a battery pack which is much cheaper than the Electrolyser-

Fuel Cell system of the comparable energy storage capacity (USD 25,000 vs USD 200,000), refer to the cases A)a; B)-C), respectively. The need for seasonal energy storage arises at the locations away from the Equator. The simplest and most cost-effective way to deal with the seasonal energy storage in these locations is the Grid energy storage (see the case A)b; B, respectively).

When the Grid energy storage is not available (case A)b; C)a and C)b.), the cheaper solution is Energy Storage in Hydrogen rather than in Li-hydrate Battery, however, the size of H2 storage tanks (66 m3) might result in safety concerns if located near a high rise building. Considering 2 m diameter tanks the total length of tanks would be about 21 m.

A careful layout planning will be required if such solution is adopted, assuming that the high cost is not an issue. Seasonal energy storage in a Battery Pack is the most expensive of all considered scenarios. It is relatively safe, but still requires considerable amount of real estate space to house the batteries. The expected battery mass is 214 tons while the battery storage volume would be around 200 m3, including the space for connections and cooling.

The overall conclusion is that the grid-independent lift energy supply system is possible, however the cost and space requirements are major limitations in the seasonal energy storage in Hydrogen form.

It should also be noted that there are hazards associated with the application of fuel cell technology in the built environment. The main hazards involved are related to the hazardous properties of hydrogen and its storage [6]. The hazards include fire and explosion as well as electrical hazards. Therefore, controlling the risks involved need to be considered.

Table 2 Comparison of Scenarios

Category	Unit	Scenarios			
		A)-a. Equator Locations	A)-b. 52° N Locations		
		B)-C) No Grid Storage Required	B) Grid Storage Possible	C) Grid Storage Not Possible	
a. Energy in Battery	b. Energy in H2				
Technical Data					
Lift Peak Power	[kW]	165	165	165	165
Buffer Battery Size	[kWh]	79	79	10698	79
PV Panels Total Surface	[m2]	51	63	63	80
H2 Storage Size (130 bar)	[m3]	NA	NA	NA	66
H2 Production/Conversion Hardware (Reversible Fuel Cell - projection)	[kW]	NA	NA	NA	24
Cost Estimate					
Buffer Battery Cost	[USD]	14,103	14,103	> 2 mln	14,103
PV Panels Cost (@ \$0.65/W)	[USD]	10,988	13,556	13,556	17,220
H2 Storage Cost	[USD]	NA	NA	NA	> 100,000
H2 Production/Conversion Hardware Cos	[USD]	NA	NA	NA	>200,000
Total Cost Estimate	[USD]	25,091	27,659	> 2 mln	> 300,000

REFERENCES

[1] J.P. Andrew and S. Kaczmarczyk, *Systems Engineering of Elevators*. Elevator World, Mobile, AL (2011).

[2] Worldatlas.com <https://www.worldatlas.com/articles/how-long-is-a-day-at-the-equator.html> ((Accessed 15 February 2020))

- [3] L. Al-Sharif, R. Peters, R. Smith, "Elevator energy simulation model". *Elevator Technology 14. Proceedings of ELEVCAN 2004*, Istanbul, Turkey, April 2004, 11-20.
- [4] M.L. Siikonen, "On Traffic Planning Methodology". *Elevator Technology 10. Proceedings of ELEVCAN 2000*, Berlin, Germany, May 2000, 267–274.
- [5] V.N. Fateev et al., *High pressure PEM water electrolysis and corresponding safety issues*. International Journal of Hydrogen Energy 36(3) • February 2011.
- [6] Health and Safety Guidance HSG243, *Fuel cells. Understand the hazards, control the risks*. Health and Safety Executive, 2004.

BIOGRAPHICAL DETAILS

Dr Stefan Kaczmarczyk is Professor of Applied Mechanics and Postgraduate Programme Leader for Lift Engineering at the University of Northampton, UK. His expertise is in the area of applied dynamics and vibration with particular applications to vertical transportation and material handling systems. He has published over 100 journal and international conference papers in this field. He is a Chartered Engineer, elected Fellow of the Institution of Mechanical Engineers and a Fellow of the Higher Education Academy.

Dr Janusz Blaszczyk is a Mechanical and Power Engineering graduate. For the past 40 years he was developing and improving technologies and products related to power generation and alternative energy: thermal processes (heat exchange & combustion), internal combustion engines, steam power boilers and fuel cell power units for various applications - automotive engines, backup power units, portable power units and auxiliary power units. His functions and positions included: Research Development Engineer, Product Development Engineer, Performance Engineer, Process Engineer, Lecturer (Thermal Subjects), Project/Program Manager, Product Development Technical Leader, Functional Manager – Mechanical Engineering, Principal Applied Scientist and Chief of Engineering. Dr Blaszczyk spent 17 years in academia environment lecturing at Silesian Technical University (Poland), University of Zimbabwe (Zimbabwe) and University of British Columbia (Canada). His recent career years were devoted to the new technologies development while working for Utility & Recovery Engineering Ltd. (Canada), Ballard Power Systems Inc. (Canada), PowerCell Ltd. (Volvo subsidiary, Sweden) and Shanghai Everpower Technologies Ltd. (China). Dr. Blaszczyk have overseen entire lifecycle of new product development – from conceptualization and R&D, through prototyping and testing to transfer for production.

Dr H. Lei Mr. his Ph.D. degree in Power Electronics from the Zhejiang University in China. He has twenty years of research and development experience, including outstanding achievements related to the development of "multi-frequency power converter topology and control" and "1-2kW UPS digital control" electronic boards. Dr. Hu Lei has worked several years as a team leader at the Fuel Cell Division at Samsung, accomplishing "2W passive Fuel Cell charger system for a cellphone" and "25W portable Fuel Cell Power Supply" for military application. Recently Dr. Hu Lei has been promoted to the position of Director of Transportation Division at Shanghai Everpower Technologies, Ltd.

Dr Rory Smith has over 49 years of experience in all aspects of the lift industry including sales, installation, maintenance, manufacturing, engineering, research & development. He has worked for ThyssenKrupp Elevator for the last 23 years. Prior to becoming involved in ThyssenKrupp's Internet of Things, he was Operations Director, ThyssenKrupp Elevator Middle East. His scientific interests include, operations management, high rise - high speed technology, ride quality, traffic analysis, dispatching. To date he has been awarded numerous patents in these areas and has many pending patents.